

GENERAL CHARACTERISTICS

Nominal Overall Diameter	307	mm
Nominal Voice Coil Diameter	38	mm
Magnet Weight	810	g
Flux Density.....	1.15	T
Weight.....	3.27	Kg

THIELE-SMALL PARAMETERS

Voice Coil DC Resistance	R_E	6.50	Ω
Resonance Frequency	f_s	112.0	Hz
Mechanical Q Factor.....	Q_{MS}	7.01	
Electrical Q Factor.....	Q_{ES}	1.05	
Total Q Factor	Q_{TS}	0.92	
Mechanical Moving Mass	M_{MS}	25.2	g
Mechanical Compliance	C_{MS}	82	μm/N
Force Factor	$B \times l$	10.39	Wb/m
Equivalent Acoustic Volume.....	V_{AS}	27.6	lt.
Maximum Linear Displacement	X_{MAX}	+/-1.0	mm
Reference Efficiency	η_0	3.48	%
Diaphragm Area	S_D	490.8	cm ²
Losses Electrical Resistance.....	R_{ES}	42.5	Ω
Voice Coil Inductance @ 1kHz	L_E	0.90	mH

CONSTRUCTIVE CHARACTERISTICS

Magnet.....	Ferrite
Voice Coil Winding.....	Copper
Voice Coil Former.....	Kapton
Cone	Paper
Surround.....	Paper - Integrated
Dust Dome	Solid Paper
Basket	Pressed Sheet Steel

ELECTRICAL CHARACTERISTICS

Nominal Impedance.....	8	Ω
Musical Power	100	W
Rated Power*	50	W
Sensitivity @ 1 W, 1 m	98.4	dB

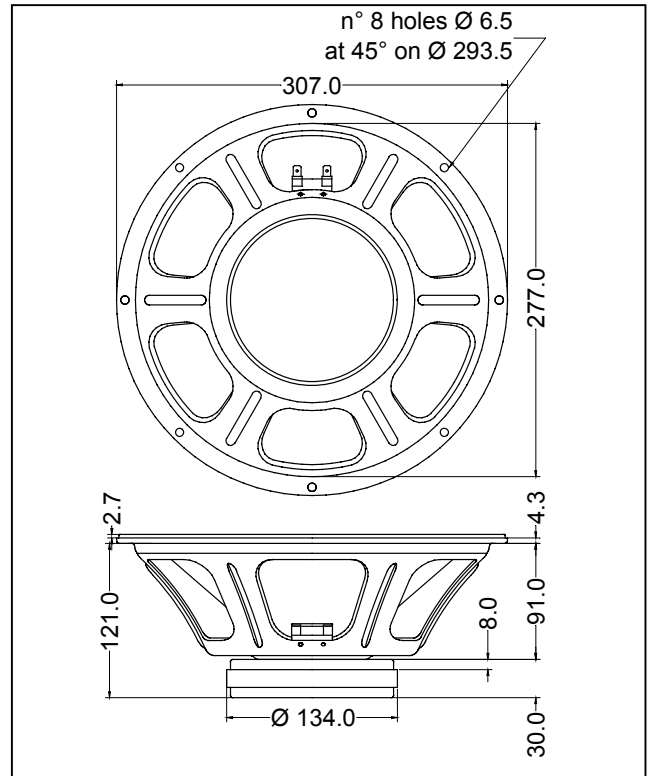

*rated power measured with 2 hours test with pink noise signal, 6 dB crest factor, loudspeaker mounted on enclosure

Frequency Response on IEC Baffle (DIN 45575) @ 1 W, 1 m - Impedance

