

12" - 70W Vintage Ceramic Loudspeaker

C 12 Q - 8 Ω

Code ZJ06180

GENERAL CHARACTERISTICS

Nominal Overall Diameter	306	mm
Nominal Voice Coil Diameter	32	mm
Magnet Weight	426	g
Flux Density.....	0.92	T
Weight.....	1.85	Kg

THIELE-SMALL PARAMETERS

Voice Coil DC Resistance	R_E	6.36	Ω
Resonance Frequency	f_s	87.3	Hz
Mechanical Q Factor.....	Q_{MS}	13.14	
Electrical Q Factor.....	Q_{ES}	1.94	
Total Q Factor	Q_{TS}	1.69	
Mechanical Moving Mass	M_{MS}	25.5	g
Mechanical Compliance	C_{MS}	130	μm/N
Force Factor	$B \times l$	6.78	Wb/m
Equivalent Acoustic Volume.....	V_{AS}	44.1	lt.
Maximum Linear Displacement	X_{MAX}	+/-1.5	mm
Reference Efficiency	η_0	1.45	%
Diaphragm Area	S_D	490.8	cm ²
Losses Electrical Resistance.....	R_{ES}	43.2	Ω
Voice Coil Inductance @ 1kHz	L_E	0.63	mH

CONSTRUCTIVE CHARACTERISTICS

Magnet.....	Ferrite
Voice Coil Winding.....	Copper
Voice Coil Former.....	Epotex
Cone	Paper
Surround.....	Paper - Integrated
Dust Dome	Solid Paper
Basket	Pressed Sheet Steel

ELECTRICAL CHARACTERISTICS

Nominal Impedance.....	8	Ω
Musical Power	70	W
Rated Power*	35	W
Sensitivity @ 1 W, 1 m	94.6	dB

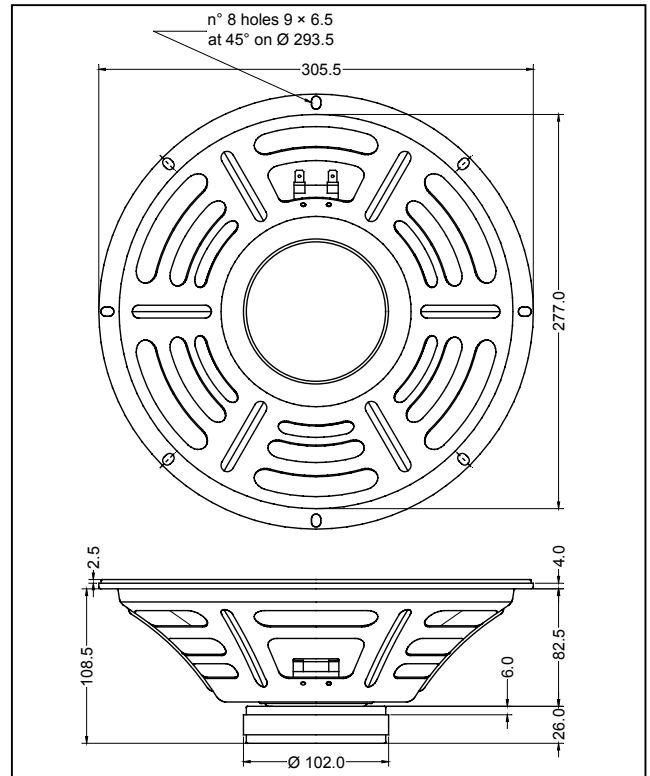

*rated power measured with 2 hours test with pink noise signal, 6 dB crest factor, loudspeaker mounted on enclosure

Frequency Response on IEC Baffle (DIN 45575) @ 1 W, 1 m - Impedance

